



As you sow, so shall you reap

YANCO AGRICULTURAL HIGH SCHOOL

Newsletter

UPCOMING EVENTS

19th December, 2018
Term 4, Week 10

Private Mail Bag
YANCO NSW 2703
EMAIL: yancoag-h.school@det.nsw.edu.au

Ph: 02 66951 1500
Fax: 02 6955 7297

Dec 19

Speech Day.
Students Travel home for end of year holidays

2019

Jan 30

All students return to school.
Year group meetings

Jan 31

Day 1 Term 1

Feb 15

Swimming Carnival

Feb 26

Open Day

Feb 28

DESI Travel Day

March 4

DESI Return Travel Day

March 8

Beach Carnival

March 9

Gala Day

April 12

End of Term 1.

YANCONIAN OF THE YEAR



Lindsay Brown



Bryce Johnston

Congratulations Lindsay and Bryce. A well deserved honour.

Merry Christmas

CONGRATULATIONS 2019 SCHOOL CAPTAINS



Captains: Lachlan Hughes and Ireland Clancy



Vice Captains: Ryan Findlay and Sophie Ryan



NOTICE BOARD

REMINDER

Permission notes for weekend activities must be in by close of school Friday afternoon (4pm). Emails are not monitored over the weekend. School office hours are 8am - 4pm for email communications. Please help us to help you. Emails sent over the weekend are not received until Monday morning.

ABSENTEE NOTIFICATION

If your child is going to be absent from school for any reason please call or email the front office with this information. All absentee information must come through our front office administration by phone on 6951 1500 or email yancoag-h.admin@det.nsw.edu.au in order for your child's absence to be recorded correctly. Weekend leave is to be handed in and signed by Wednesday each week. Duty staff are better able to check student numbers when these simple rules are followed.

Office hours are from 8am – 4pm Monday to Friday. After 4pm the phone will be answered by Duty Staff.

When returning your child to school PLEASE remember to sign them back in at the front office between the hours of 8am – 3pm. After school hours sign in at the Duty Room (before 8am and after 3pm). They will be marked absent if not signed in.

Where a student is absent from school, a note explaining the absence must be received by the school within **seven** school days. Where a note is not received the absence will be recorded as **Unjustified Leave**. This cannot legally be changed should a note be received after **seven** days.

PLEASE name your childrens' uniforms and casual clothing . When clothing goes missing it easier to return it to the rightful owners when labelled! We cannot be responsible for unnamed clothing going missing.

CHANGE OF DETAILS

If your **contact details have changed at all** please contact the Front Office, by email, with your new details.



Returning to school in 2019 YEAR 10

If you think your child will not be returning for Year 11 2019 we ask that you please inform the school as soon as possible.

Thank you

PRINCIPAL'S REPORT

As everyone should be aware the school, students, have achieved some great results in their Higher School Certificate this year. Congratulations to all those students who achieved a Band 6, higher than 90% and those who achieved a Band 5, higher than 80%, in their final results. Considering the small candidature number these were excellent results. Congratulations to all other students who received early entry to courses and achieved beyond their expectations.

These final weeks of school have been even busier than normal with all the work going on in dormitories and the grounds. Over the Christmas period new Bain Maries will be installed in the dining room; work on lighting for the tennis courts will be upgraded; tiling around McCaughey House; bathrooms in Hindmarsh; as well as work beginning on Mutch dorm; barbecue completed as well as more work on exclusion fencing.

Plans for next year include more money spent on upgrading dormitory facilities, completion of exclusion fencing, planning for Agriculture laboratory and seeking support for building of new girl's dormitory after 25 years of being in demountable buildings.

As usual at the end of each year we are saying goodbye to numerous staff who have contributed to our school. Mr Matt Shady will be working at Narrandera High next year and will be missed in the Agriculture Faculty. Mr Peter Stanley and Mr Brenton O'Brien will both be moving on. Mrs Danielle Ingram is moving on to Borellan Central in a full time position while Ms Hannah Jolley is moving to the Canberra area. Mrs Sharon Greene who is the Science assistant is moving to Orange with her family. I would like to thank all staff for their tireless contribution to the school in their time here and wish them all the best for the future.

New staff for next year include Ms April Worland who replaces her brother Chris in the TAS faculty. Mrs Danielle Ganderton who will be the school's Learning and Support Teacher as well as LOTE. Mr Andrew Ganderton in Science and Mr Braydon Gillard who will work in the Agriculture faculty and Ms Emily Caldwell in the English faculty.

I look forward to seeing what the school can accomplish next year and wish everyone a Merry Christmas and a Happy New Year.

Gary Hunt



2018 HSC RESULTS

Yanco students have achieved some pleasing results in the 2018 Higher School Certificate Examination. Highlights include;

Two Students in Top Achievers List

- Lindsay Brown 2nd in State for Primary Industries
- Jayden Pippin Equal 4th in State for Metals and Engineering

Eight Students on Distinguished Achievers List

- Lindsay Brown Agriculture, Primary Industries and Biology
- Seb Clarke Visual Arts and Major Work selected in **Art Express** Exhibition
- Kiara Henderson Primary Industries
- Bryce Johnston Agriculture, Industrial Technology and Primary Industries
- Abbey McCloskey Agriculture
- Lyndsey Mitchell Agriculture
- Jayden Pippin Metals and Engineering
- Kiera Whitehead Agriculture and Physical Development/Health/Physical Education

In addition, Yanco Agricultural High School ranked Equal First in NSW for the number of students achieving Band 6 results in Primary Industries and Equal Fifth in NSW for the number of students achieving a Band 6 result in Agriculture.

Congratulations to these students, the entire 2018 cohort and staff on this impressive result.

CONGRATULATION SEB CLARKE

ARTEXPRESS is an annual exhibition program featuring exemplary bodies of work from the New South Wales Higher School Certificate Visual Arts examination. It is a joint venture between the office of the Board of Studies Teaching and Educational Standards, New South Wales and the New South Wales Department of Education, managed by the Department's Arts Unit.

ARTEXPRESS aims: To create high quality exhibitions of exemplary HSC Bodies of Work for metropolitan and regional NSW galleries that:

- Offer a quality teaching and learning resource
- Celebrate the talent of NSW HSC Visual Arts students and teachers
- Connect with communities through the Visual Arts

From 8,770 students who submitted Bodies of Works for the HSC Visual Arts Examination 402 students were nominated for ARTEXPRESS. From these nominations 240 bodies of work were selected to create nine exhibitions, representing schools from across NSW.

SPORTS REPORT

Alice Caldwell of Year 7 travelled across to Wagga on Friday to trial for the Riverina Opens Girls Cricket Team. Alice was one of the youngest there, trialing against girls in Years 7-11. Alice was successful in making it in the team as 1st reserve. This is an excellent achievement for such a young athlete. Congratulations Alice.

Angus Boulton was successful in making it into the Riverina Open Boys Cricket team at the end of last term. This is an amazing achievement for Angus. Congratulations.

Jock Yelland was selected again this year to represent the Under16's Murrumbidgee Cricket team at the Riverina Carnival in Albury. This was held over the November DESI weekend. Congratulations Jock.

TAS REPORT

Metals and Engineering

The Year 11 students have been progressing well this year and as a Term 4 project they are busy manufacturing forty new panels for the school's sheep yards. The original set was manufactured some years ago and with the increase in demand with the ram sale etc. the school needed to expand the capacity of the yards. Part of the metals workshop has been set up as a production line with students rotating through the stations to demonstrate repeated and consistent competency in a variety of skills.

The stations are: 2 X Measure & Cutting, 3 X Assembly using a jig (tack welding the frame together) and 2 X Solid Welding. Due to our excellent resources at YAHS we are able to have several students doing the same process but on different machines.



Jacob at a cutting bay



Hayden at the assembly jig



Charlie on final welding



A bit over half way

STAGE 4 TECHNOLOGY

The Year 8 students have been learning Coding (computer programming) this year. The current group have entered the Premier's Coding Challenge which is a programme of selected schools to work through different levels with the top level, Diamond, for automated inventions. YAHS has entered four teams and they are creating a scale model farm with automated gates, irrigation stop gates and one team is aiming to make a tractor that autonomously navigates the farm and identifies "insects" on a crop and sprays only the insects.

The current Year 7 class is working on having the lights in the farmhouse come on automatically when the sun goes down. They will then also work through a pattern of switching rooms off and on plus external floodlights.

Time may be a factor of how far we get with these but it should be possible.

STAGE 5 ENGINEERING are working toward one day entering the Formula 1 in Schools competition. They have been learning to use the Autodesk Fusion 360 3D CAD program to design a small CO2 rocket car. In Term 4 they have started manufacturing the Balsa wood car ready for an in school drag racing competition. The full competition, sponsored by Formula 1, is the largest STEM competition worldwide.

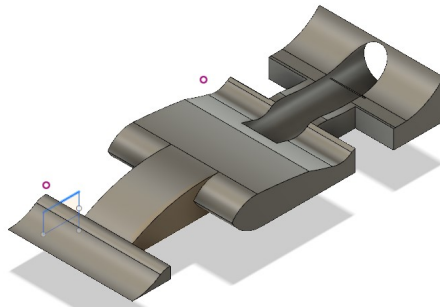

STAGE 5 METALS have many projects running at the moment. Year 10 are manufacturing their Major Project which includes a variety of projects from Chess Set, Fire Pit to Dog Pens. The students are progressing well with these and they are taking shape.

The Year 9s are progressing through a couple of projects as resources allow, including some scrolled steel hose racks and making a centre punch on the lathe.

LAMBPLAN SCANNING AND DNA TESTING

Students from Year 9 and Year 10 Animal Management spent Wednesday morning assisting Steve Milne of Richmond Hill Agribusiness scan all of the 2018 drop lambs for their eye muscle and fat muscle depth. This data will go into Lambplan to contribute to Australian Sheep Breeding Values. Students also collected DNA samples of the top thirty ram lambs, using a Tissue Sampling Unit, which takes a small circle of tissue from the ear and puts it into a sample container for analysis. The genetic sequence and pedigree will be analyzed at the Sheep Genetics Laboratory and returned as improved accuracy in the ASBVs. Students trialed the use of a Barcode Scanner, kindly loaned from Bel's Rural, an old Yanconian, to scan the samples and record them in our Stockbook data management software.

The P & C have kindly donated the funds to purchase a barcode scanner and label printer.

Ellie Quinn / Agriculture Teacher



DEFENCE FORCE RECRUITMENT

Six Students from Years 10 and 11 are currently taking part in an Australian Defence Force Your Opportunities Unlimited (YOU) session. The YOU session is the first step in a recruitment process into the Defence Force. In this session students complete a medical questionnaire and test, take and aptitude test and talk to a careers coach about the services and roles the student may be considering. It is a great opportunity for students to look at what options they may have with the ADF in the near future.



Jett Crouch, Jack Dickson, Sophie Ryan, Emma Dixon, Brook-Lyn Johnston and Charlie Woods

Nathan Cassilles | Careers Adviser

ATV SAFETY COURSE

Year 11 Certificate III in Agriculture students recently spent 2 days gaining skills in the safe and responsible use of ATVs and two wheel motor bikes here at Yanco Ag. They identified their limitations in terms of rider ability and also that of the machines they were using. Students successfully completed the course and are now able to recognise risks and hazards enabling them to implement safety measures when using quad bikes on farms.

Luke Collins | Head Teacher Agricultural





2019 STUDENT RETURN TO SCHOOL TIMES

Wednesday 30th January, 2019.

Students Return to school and attend the following meetings

- 9:00 am School Opens
- 10:00 am Year 7 and 8 Students and Parents meeting
- 10.35 am Year 9 Students and Parents meeting
- 10:55 am Year 10 Students and Parents meeting
- 11:15 am Year 11 Students and Parents meeting
- 11:35 am All VET Students
- 12:10 pm Year 12 Students and Parents meeting
- 12:30 pm P & C meeting
- 2:00 pm All students and parents involved in the Equine Program

ALL MEETINGS WILL BE HELD IN THE SCHOOL HALL

Classes will commence Thursday 31st January

YAHS TWILIGHT SWIMMING CARNIVAL

FEBRUARY 15th 2019

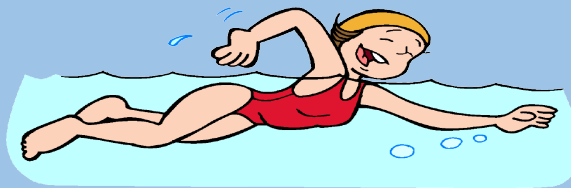
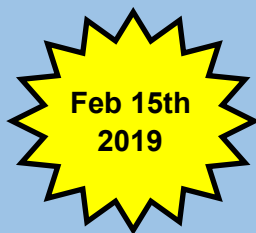

BEACH CARNIVAL March 8th

GALA DAY March 9th

YEAR 10 LEADERSHIP CAMP



BACK TO SCHOOL 2019

January 30th

Students return to school

January 31st

Classes commence

February 15th

Twilight Swimming Carnival

February 26th

Open Day

February 28th

DESI Weekend

March 8th

Beach Carnival

March 9th

Gala Day



These are a few events taking place in early Term 1 2019 which you might like to mark on your calendar. It is always an opportunity to spend time with your children within the school environment

YEARS 7, 8 and 9 END OF YEAR EXCURSIONS



SCHOLARSHIP INFORMATION

FACS is offering \$1,000 scholarships to students enrolled in education or training in 2019. The scholarships help young people complete their studies and reach their full potential.

This year it is easier and faster to apply than ever:

A range of people can now support the student's application. This includes a parent, carer, guardian, caseworker, support work or someone from school.

Students no longer need to print out and upload paper forms.

For students who have received a scholarship in 2017 an/or in 2018:

There's no need to fill out the full application. Students only need to confirm their eligibility, and update their contact details (if they have changed).

Key dates

- Applications open at 9am on Monday 17 December 2018.
- or Year 10, 11 or 12 students, applications will close at 5pm on Friday 19 January 2019.
- For returning students attending a TAFE college, university or in a traineeship/ apprenticeship in 2019, applications close at 5pm on Friday 1 March 2019.

For more information, please visit www.facs.nsw.gov.au/facs-scholarships.

If you have any questions or enquiries please contact 02 8753 8673 or email education@facs.nsw.gov.au.

TERM 1 2019

Day1 Term 1 **Thursday January 31st**

DESI

Students travel home **Thursday February 28th**

Students return **Monday March 4th**

Last Day Term 1 **Friday April 12th**



CHRISTMAS WISHES

From all Yanco Agricultural High School staff and teachers we would like to wish our students and their families a very safe and happy holiday.



**Merry Christmas and a Happy New Year.
We look forward to seeing you back here in 2019**



SchoolTV - A Parent Resource

It has never been more challenging for parents to raise happy, healthy and resilient children. Like never before, parents need to be informed with clear, fact-based information on the many challenges faced by today's youth. Topics such as youth anxiety, depression, self-harm, drug and alcohol use, cyberbullying and many others need clear explanation and guidance.

SchoolTV is a new ongoing resource that is now available to our parents. Each edition will address a major topic with expert interviews, fact sheets, parent quiz, recommended apps, books and much more. SchoolTV aggregates information from many great resources such as BeyondBlue and ReachOut, amongst others. SchoolTV provides a single stream of independent factual information that saves parents time and confusion of searching online across multiple sites for information.

You can access the SchoolTV archive here:

<https://yancoag-h.schools.nsw.schooltv.me/category-latest-newsletter>

Depression, Anxiety, Cyberbullying, Drugs, Alcohol...

Some of the challenges faced by today's parents.



SchoolTV is a new resource designed to inform and support parents on major issues with contributions from Australia's leading experts.